

ECE 461 – Internetworking Fall 2009

Problem Sheet 6

Instructions:

- Refer to the lecture slides on the Spanning Tree Protocol and the description of the Spanning Tree protocol from:
<http://www.comm.utoronto.ca/~jorg/teaching/ece461/handouts/spt.pdf>

Problem 1. Consider Bridge 80 with 5 ports as shown in the figure below. The bridge is receiving configuration messages (BPDUs) as shown in the Figure. Specifically, a message (R, C, B, P) where R is the value of the root ID, C is the value of the root path cost, B is the bridge ID, and P is the port ID, is interpreted as follows: “I am bridge B and I am sending from my port P. I believe R to be the root bridge, and the cost of my path to the root bridge is C.”

- What is the root of Bridge 80?
- What is the Root Path Cost of Bridge 80?
- What is Bridge 80’s root port?
- What is Bridge 80’s configuration message?
- For which, if any, is Bridge 80 the designated bridge?
- Which ports of Bridge 80 are marked as “blocked”?

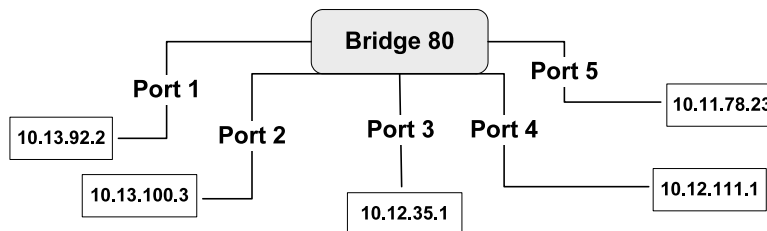

Problem 2. Bridges / LAN switches

Figure 2 shows a network of bridges and LANs. The bridges run the IEEE 802.1d spanning tree algorithm. The Bridge IDs are “1” for Bridge 1, “2” for Bridge 2, etc.

Assume that all bridges send out their BPDU’s once per second, and assume that all bridges send their BPDUs at the same time. Assume that all bridges are turned on simultaneously at time T=0 sec.

- a. Use the following table to write the BPDUs which are sent by the bridges. For each cell, include:
- the BPDU (For each BPDU, only provide the <root, cost, bridge> fields)
 - the ports on which the BPDUs is transmitted (write “none” if the BPDU is not sent on any of the ports).

	Bridge1	Bridge2	Bridge3	Bridge4	Bridge5	Bridge 6
T=0sec						
T=1sec						
T=2sec						

- b. After the spanning tree algorithm has converged, provide the following information for each bridge:
- Which is the root port?
 - Which, if any, are designated ports of a bridge?
 - Which, if any, are blocked ports.

	Bridge1	Bridge2	Bridge3	Bridge4	Bridge5	Bridge 6
Root Port						
Designated Ports						
Blocked ports						

- c. Draw the spanning tree in Figure 2.

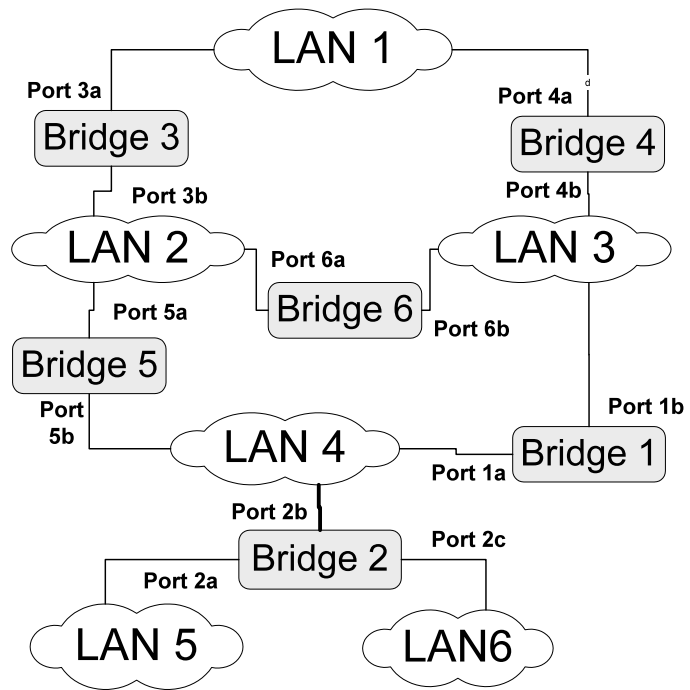

Figure 2.