

<http://www.comm.utoronto.ca/~dkundur/course/discrete-time-systems/>

HOMEWORK #3 - SOLUTIONS

4.13

Recall that the Fourier transform $X(\omega)$ of a signal $x(n)$ is given by:

$$X(\omega) = F[x(n)] = \sum_{n=-\infty}^{\infty} x(n) \cdot \exp(-j\omega n)$$

Therefore from example 4.4.2, the Fourier transform of the signal $x(n) = \begin{cases} 1 & -M \leq n \leq M \\ 0 & \text{otherwise} \end{cases}$ is

$$X(\omega) = 1 + 2 \cdot \sum_{n=1}^M \cos(\omega n).$$

The Fourier transform of the signal $x_1(n) = \begin{cases} 1 & 0 \leq n \leq M \\ 0 & \text{otherwise} \end{cases}$ is given by:

$$X_1(\omega) = F[x_1(n)] = \sum_{n=-\infty}^{\infty} x_1(n) \cdot \exp(-j\omega n) = \sum_{n=0}^M \exp(-j\omega n) = \sum_{n=0}^M [\exp(-j\omega)]^n$$

$$i.e., \quad X_1(\omega) = \frac{1 - \exp(-j\omega(M+1))}{1 - \exp(-j\omega)}$$

The Fourier transform of the signal $x_2(n) = \begin{cases} 1 & -M \leq n \leq -1 \\ 0 & \text{otherwise} \end{cases}$ is given by:

$$X_2(\omega) = F[x_2(n)] = \sum_{n=-\infty}^{\infty} x_2(n) \cdot \exp(-j\omega n) = \sum_{n=-M}^{-1} \exp(-j\omega n) = \sum_{n=-M}^{-1} [\exp(-j\omega)]^n = \sum_{n=1}^M [\exp(j\omega)]^n$$

$$i.e., \quad X_2(\omega) = \frac{1 - \exp(j\omega M)}{1 - \exp(j\omega)} \cdot \exp(j\omega)$$

Adding the two Fourier transforms $X_1(\omega)$ and $X_2(\omega)$ we get:

$$\begin{aligned} X(\omega) = X_1(\omega) + X_2(\omega) &= \frac{[1 - \exp(-j\omega(M+1))] \cdot [1 - \exp(j\omega)] + [\exp(j\omega) - \exp(j\omega(M+1))] [1 - \exp(-j\omega)]}{[1 - \exp(-j\omega)] \cdot [1 - \exp(j\omega)]} \\ &= \frac{[\exp(j\omega M) + \exp(-j\omega M)] - [\exp(j\omega(M+1)) + \exp(-j\omega(M+1))]}{2 - [\exp(j\omega) + \exp(-j\omega)]} \\ &= \frac{2 \cdot \cos(\omega M) - 2 \cdot \cos(\omega(M+1))}{2 - 2 \cdot \cos(\omega)} \end{aligned}$$

Or equivalently:

$$X(\omega) = \frac{\sin\left(\left(M + \frac{1}{2}\right) \cdot \omega\right)}{\sin\left(\frac{\omega}{2}\right)}$$

4.16

The signal that we have to consider is $a^n u(n)$ with Fourier transform $\frac{1}{1 - a \cdot \exp(-j\omega)}$, $|a| < 1$.

The differentiation in frequency theorem states that if $x(n) \stackrel{F}{\leftrightarrow} X(\omega)$, then $n \cdot x(n) \stackrel{F}{\leftrightarrow} j \frac{dX(\omega)}{d\omega}$.

We want to prove that $\frac{(n+l-1)!}{n!(l-1)!} a^n u(n) \stackrel{F}{\leftrightarrow} \frac{1}{(1 - a \cdot \exp(-j\omega))^l}$

Let's proceed by induction by first proving that the property is true for $l=1$:

$$\left. \frac{(n+l-1)!}{n!(l-1)!} a^n u(n) \right|_{l=0} = \frac{n!}{n!} a^n u(n) \stackrel{F}{\leftrightarrow} \frac{1}{(1 - a \cdot \exp(-j\omega))}$$

Then suppose that the following property holds:

$$x_k(n) = \frac{(n+k-1)!}{n!(k-1)!} a^n u(n) \stackrel{F}{\leftrightarrow} \frac{1}{(1 - a \cdot \exp(-j\omega))^k} = X_k(\omega)$$

And finally, let's compute $x_{k+1}(n)$:

$$x_{k+1}(n) = \frac{(n+(k+1)-1)!}{n!((k+1)-1)!} a^n u(n) = \frac{(n+k)!}{n!k!} a^n u(n) = \frac{n+k}{k} x_k(n) = x_k(n) + \frac{n}{k} x_k(n)$$

This result and the differentiation in frequency theorem lead us to the following:

$$\begin{aligned}
x_k(n) + \frac{n}{k} x_k(n) &\stackrel{F}{\leftrightarrow} X_k(\omega) + \frac{1}{k} \cdot \left(j \frac{dX_k(\omega)}{d\omega} \right) = \frac{1}{(1 - a \cdot \exp(-j\omega))^k} + \frac{a \cdot \exp(-j\omega)}{(1 - a \cdot \exp(-j\omega))^{k+1}} \\
&= \frac{(1 - a \cdot \exp(-j\omega)) + a \cdot \exp(-j\omega)}{(1 - a \cdot \exp(-j\omega))^{k+1}} \\
&= \frac{1}{(1 - a \cdot \exp(-j\omega))^{k+1}} = X_{k+1}(\omega)
\end{aligned}$$

The property was proven to be true for $l=1$ then was supposed true for $l=k$ and was proven to be true for $l=k+1$, we can then infer that it is true for all l .

$$\frac{(n+l-1)!}{n!(l-1)!} a^n u(n) \stackrel{F}{\leftrightarrow} \frac{1}{(1 - a \cdot \exp(-j\omega))^l}$$

4.17

Recall the Fourier transform, $X(\omega)$, of a signal $x(n)$ is given by $X(\omega) = F[x(n)] = \sum_{n=-\infty}^{\infty} x(n) \cdot \exp(-j\omega n)$

(a) The signal to consider is $x^*(n)$.

$$F[x^*(n)] = \sum_{n=-\infty}^{\infty} x^*(n) \cdot \exp(-j\omega n) = \left(\sum_{n=-\infty}^{\infty} x(n) \cdot \exp(-j(-\omega)n) \right)^* = X^*(-\omega)$$

$$\Rightarrow x^*(n) \stackrel{F}{\leftrightarrow} X^*(-\omega)$$

(b) The signal to consider is $x^*(-n)$.

$$\begin{aligned}
F[x^*(-n)] &= \sum_{n=-\infty}^{\infty} x^*(-n) \cdot \exp(-j\omega n) = \left(\sum_{n=-\infty}^{\infty} x(-n) \cdot \exp(-j(-\omega)n) \right)^* \\
&= \left(\sum_{n'=-\infty}^{\infty} x(n') \cdot \exp(-j(-\omega)(-n')) \right)^* \quad (\text{with } n' = -n) \\
&= \left(\sum_{n'=-\infty}^{\infty} x(n') \cdot \exp(-j\omega n') \right)^* = X^*(\omega)
\end{aligned}$$

$$\Rightarrow x^*(-n) \stackrel{F}{\leftrightarrow} X^*(\omega)$$

(c) The signal to consider is $y(n) = x(n) - x(n-1)$.

$$\begin{aligned}
 F[y(n)] &= \sum_{n=-\infty}^{\infty} y(n) \cdot \exp(-j\omega n) = \sum_{n=-\infty}^{\infty} [x(n) - x(n-1)] \cdot \exp(-j\omega n) \\
 &= \sum_{n=-\infty}^{\infty} x(n) \cdot \exp(-j\omega n) - \sum_{n=-\infty}^{\infty} x(n-1) \cdot \exp(-j\omega n) \\
 &= \sum_{n=-\infty}^{\infty} x(n) \cdot \exp(-j\omega n) - \sum_{n=-\infty}^{\infty} x(n) \cdot \exp(-j\omega(n+1)) \\
 &= X(\omega) - X(\omega) \cdot \exp(-j\omega) \\
 &= X(\omega) \cdot (1 - \exp(-j\omega)) = Y(\omega)
 \end{aligned}$$

$$\Rightarrow Y(\omega) = X(\omega) \cdot (1 - \exp(-j\omega))$$

(d) We have $y(n) = \sum_{k=-\infty}^n x(k)$ and therefore $x(n) = y(n) - y(n-1)$ which means that from (c)

$F[x(n)] = X(\omega) = Y(\omega) \cdot (1 - \exp(-j\omega))$ or equivalently:

$$F[y(n)] = Y(\omega) = \frac{X(\omega)}{1 - \exp(-j\omega)}.$$

(e) The signal to consider is $y(n) = x(2n)$.

$$\begin{aligned}
 F[y(n)] &= \sum_{n=-\infty}^{\infty} y(n) \cdot \exp(-j\omega n) = \sum_{n=-\infty}^{\infty} [x(2n)] \cdot \exp(-j\omega n) \\
 &= \sum_{n'=-\infty}^{\infty} x(n') \cdot \exp\left(-j\omega \left(\frac{n'}{2}\right)\right) \quad \text{with } n' = 2n \\
 &= \sum_{n'=-\infty}^{\infty} x(n') \cdot \exp\left(-j \left(\frac{\omega}{2}\right) n'\right) \\
 &= X\left(\frac{\omega}{2}\right)
 \end{aligned}$$

$$\Rightarrow Y(\omega) = X\left(\frac{\omega}{2}\right)$$

(f) The signal to consider is $y(n) = x\left(\frac{n}{2}\right)$.

$$\begin{aligned}
 F[y(n)] &= \sum_{n=-\infty}^{\infty} y(n) \cdot \exp(-j\omega n) = \sum_{n=-\infty, n \text{ even}}^{\infty} \left[x\left(\frac{n}{2}\right) \right] \cdot \exp(-j\omega n) \\
 &= \sum_{n'=-\infty}^{\infty} x(n') \cdot \exp(-j\omega(2n')) \quad \text{with } n' = \frac{n}{2} \\
 &= \sum_{n'=-\infty}^{\infty} x(n') \cdot \exp(-j(2\omega)n') \\
 &= X(2\omega)
 \end{aligned}$$

$$\Rightarrow Y(\omega) = X(2\omega)$$

4.18

(a) The signal to consider is $x_1(n) = \{1, 1, 1, 1\}$.

$$\begin{aligned}
 X_1(\omega) &= F[x_1(n)] = \sum_{n=-\infty}^{\infty} x_1(n) \cdot \exp(-j\omega n) \\
 &= \sum_{n=-2}^2 \exp(-j\omega n) \\
 &= \exp(j2\omega) + \exp(j\omega) + 1 + \exp(-j\omega) + \exp(-j2\omega) \\
 &= 1 + [\exp(j\omega) + \exp(-j\omega)] + [\exp(j2\omega) + \exp(-j2\omega)] \\
 &= 1 + 2 \cdot \cos(\omega) + 2 \cdot \cos(2\omega)
 \end{aligned}$$

$$\Rightarrow X_1(\omega) = 1 + 2 \cdot \cos(\omega) + 2 \cdot \cos(2\omega)$$

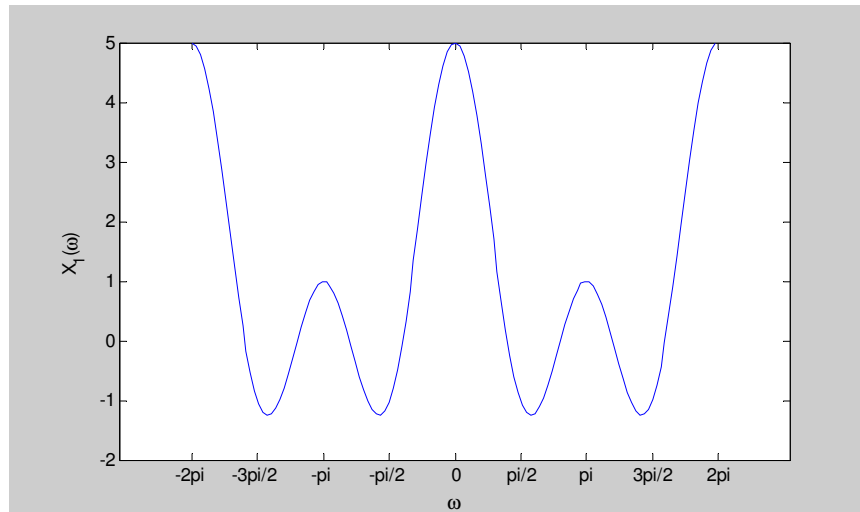

(b) The signal to consider is $x_2(n) = \{1, 0, 1, 0, \underset{\uparrow}{1}, 0, 1, 0, 1\}$.

$$\begin{aligned}
 X_2(\omega) &= F[x_2(n)] = \sum_{n=-\infty}^{\infty} x_2(n) \cdot \exp(-j\omega n) \\
 &= \sum_{n=-4}^4 x_2(n) \cdot \exp(-j\omega n) \\
 &= \exp(j4\omega) + \exp(j2\omega) + 1 + \exp(-j2\omega) + \exp(-j4\omega) \\
 &= 1 + [\exp(j2\omega) + \exp(-j2\omega)] + [\exp(j4\omega) + \exp(-j4\omega)] \\
 &= 1 + 2 \cdot \cos(2\omega) + 2 \cdot \cos(4\omega)
 \end{aligned}$$

$$\Rightarrow X_2(\omega) = 1 + 2 \cdot \cos(2\omega) + 2 \cdot \cos(4\omega)$$

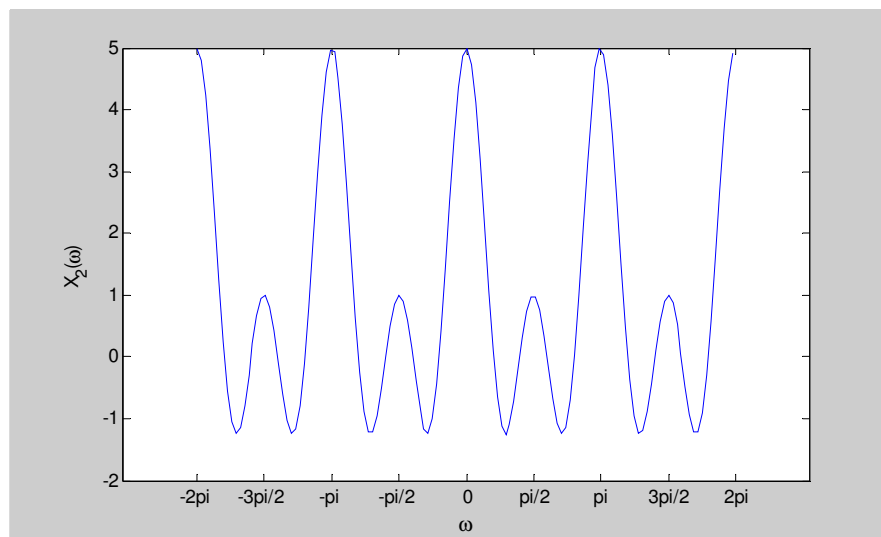

(c) The signal to consider is $x_3(n) = \{1, 0, 0, 1, 0, 0, 1, 0, 0, 1, 0, 0, 1\}$.

$$\begin{aligned}
 X_3(\omega) &= F[x_3(n)] = \sum_{n=-\infty}^{\infty} x_3(n) \cdot \exp(-j\omega n) \\
 &= \sum_{n=-6}^6 x_3(n) \cdot \exp(-j\omega n) \\
 &= \exp(j6\omega) + \exp(j3\omega) + 1 + \exp(-j3\omega) + \exp(-j6\omega) \\
 &= 1 + [\exp(j3\omega) + \exp(-j3\omega)] + [\exp(j6\omega) + \exp(-j6\omega)] \\
 &= 1 + 2 \cdot \cos(3\omega) + 2 \cdot \cos(6\omega)
 \end{aligned}$$

$$\Rightarrow X_3(\omega) = 1 + 2 \cdot \cos(3\omega) + 2 \cdot \cos(6\omega)$$

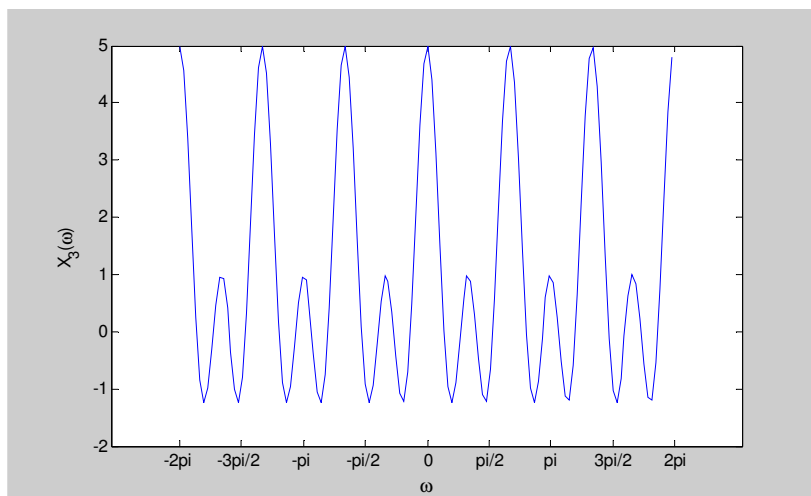

(d)

From the results obtained in (a), (b) and (c), it becomes obvious that $X_1(\omega)$, $X_2(\omega)$ and $X_3(\omega)$ are related by the following equalities:

$$X_2(\omega) = X_1(2\omega) \quad \text{and} \quad X_3(\omega) = X_1(3\omega)$$

(e) Suppose $x_k(n) = \begin{cases} x\left(\frac{n}{k}\right) & \text{if } \frac{n}{k} \in \mathbb{Z} \\ 0 & \text{otherwise} \end{cases}$, then we can write:

$$\begin{aligned}
F[x_k(n)] &= \sum_{n=-\infty}^{\infty} x_k(n) \cdot \exp(-j\omega n) = \sum_{n=-\infty, \substack{n \in Z \\ k \in Z}}^{\infty} \left[x\left(\frac{n}{k}\right) \right] \cdot \exp(-j\omega n) \\
&= \sum_{n'=-\infty}^{\infty} x(n') \cdot \exp(-j\omega(kn')) \quad \text{with } n = kn' \\
&= \sum_{n'=-\infty}^{\infty} x(n') \cdot \exp(-j(k\omega)n') \\
&= X(k\omega)
\end{aligned}$$

$$\Rightarrow X_k(\omega) = X(k\omega)$$

4.23

UPDATE: So this is my take (to take with some precaution maybe) on the question asked during the “review” session, hopefully it makes sense and helps understand the problem a little bit better.

From the hint at the end of the problem, let’s write $y_1(n) = x(n)s_1(n)$ with $s_1(n) = \{\dots, 1, 0, 1, 0, 1, 0, 1, 0, 1, \dots\}$ which is equivalent to:

$$s_1(n) = \sum_{m=-\infty}^{\infty} \delta(n - mT_s) = \sum_{m=-\infty}^{\infty} \delta(n - 2m) \quad (T_s \text{ corresponds to the interval between two impulses i.e., in that case } T_s = 2)$$

Taking the Fourier transform we get $Y_1(\omega) = X(\omega) * S_1(\omega)$ where $S_1(\omega) = \frac{2\pi}{T_s} \sum_{m=-\infty}^{\infty} \delta(\omega - m \cdot \omega_s)$ with $\omega_s = \frac{2\pi}{T_s}$ therefore $Y_1(\omega)$ is a repetition of the signal $X(\omega)$ with period π which means that $Y_1(\omega) \neq X(\omega)$.

Graphically it may be easier to understand so here it is:

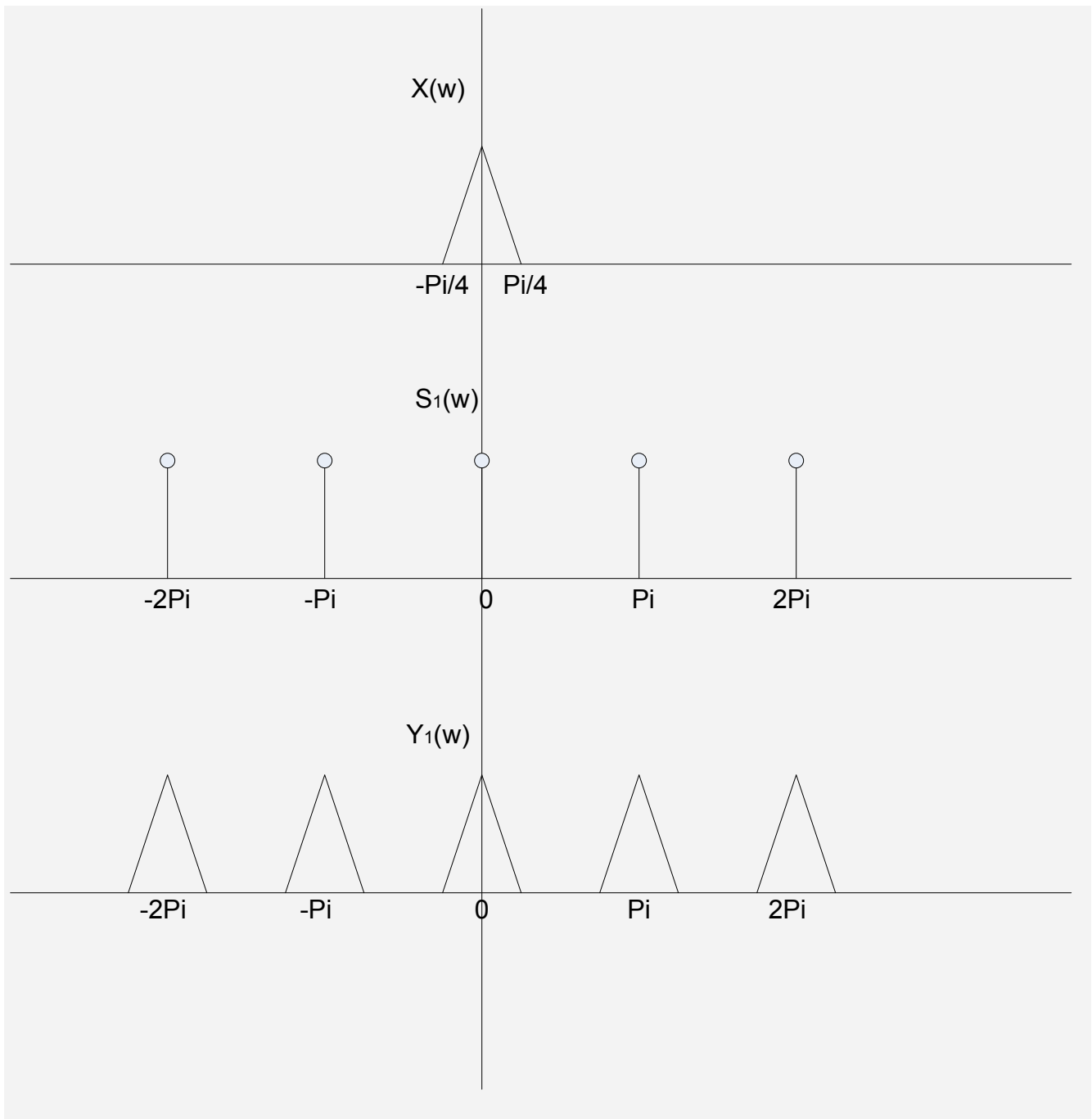

(a) We have $y_1(n) = \begin{cases} x(n) & \text{if } n \text{ even} \\ 0 & \text{otherwise} \end{cases}$ which we can rewrite considering (b) and (c) as:

$$y_1(n) = \begin{cases} y_2\left(\frac{n}{2}\right) & \text{if } n \text{ even} \\ 0 & \text{otherwise} \end{cases}$$

Therefore the resulting Fourier transform becomes:

$$Y_1(\omega) = Y_2(2\omega)$$

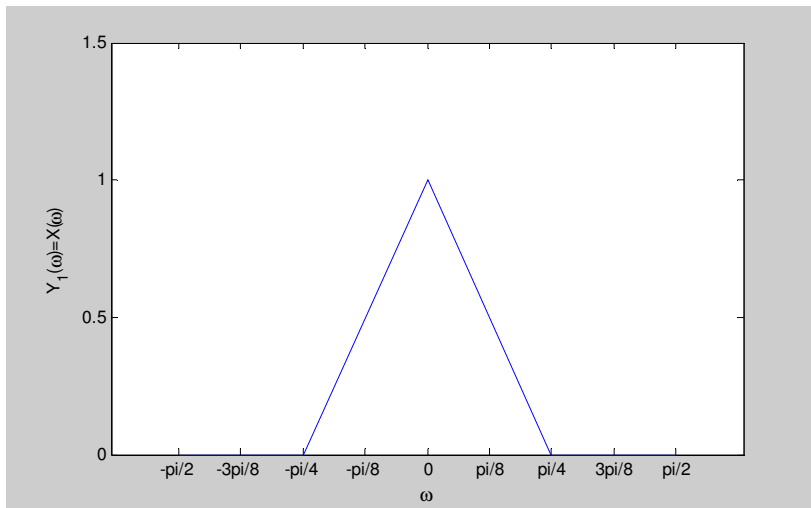

(b) From problem 4.17 (e) we know that $Y_2(\omega) = X\left(\frac{\omega}{2}\right)$.

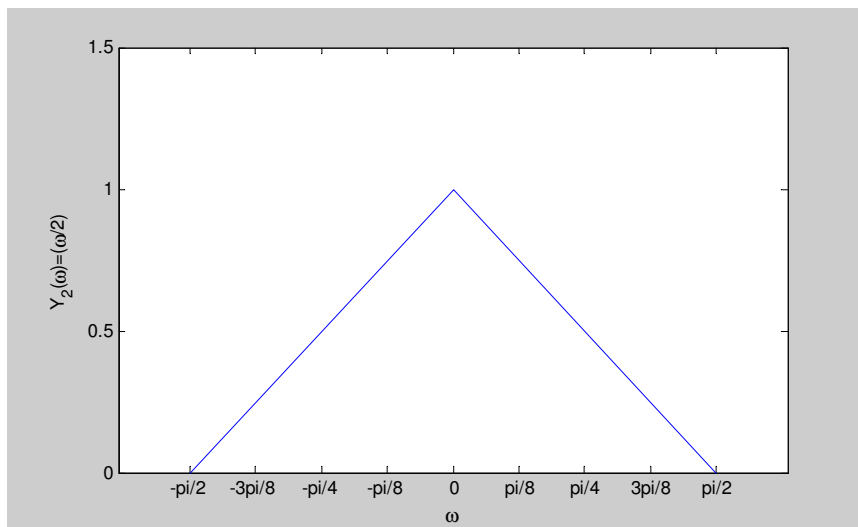

(c) From problem 4.17 (f) we know that $Y_3(\omega) = X(2\omega)$.

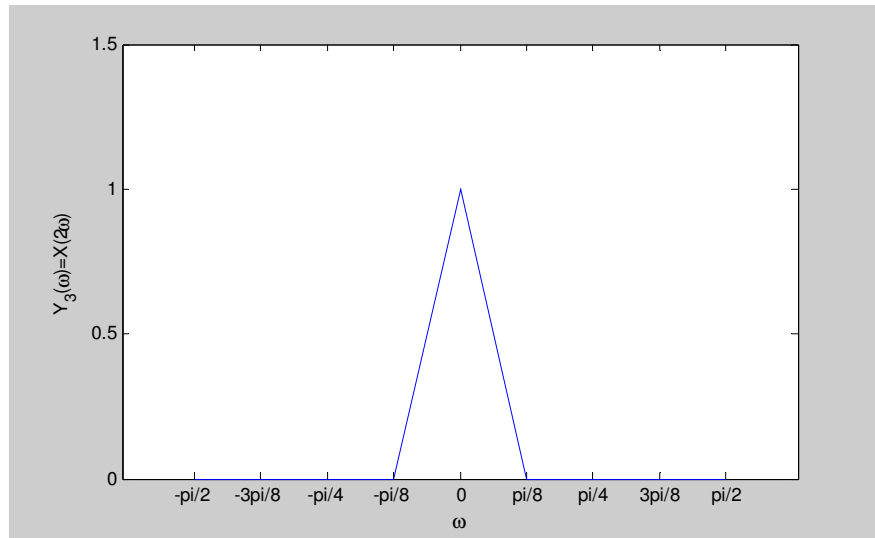

5.4

(f) The Fourier transform of the signal $y(n) = \frac{1}{2} \cdot [x(n) - x(n-2)]$ is

$Y(\omega) = \frac{1}{2} \cdot [X(\omega) - X(\omega) \cdot \exp(-2j\omega)] = \frac{1}{2} \cdot [X(\omega) \cdot (1 - \exp(-2j\omega))]$ and the corresponding filter is

$$H(\omega) = \frac{Y(\omega)}{X(\omega)} = \frac{1}{2} \cdot (1 - \exp(-2j\omega)) = j \cdot \exp(-j\omega) \cdot \frac{\exp(j\omega) - \exp(-j\omega)}{2j} = \sin(\omega) \cdot \exp\left(-j\left(\omega - \frac{\pi}{2}\right)\right)$$

Therefore

$$|H(\omega)| = |\sin(\omega)| \text{ and } \theta(\omega) = -\left(\omega - \frac{\pi}{2}\right)$$

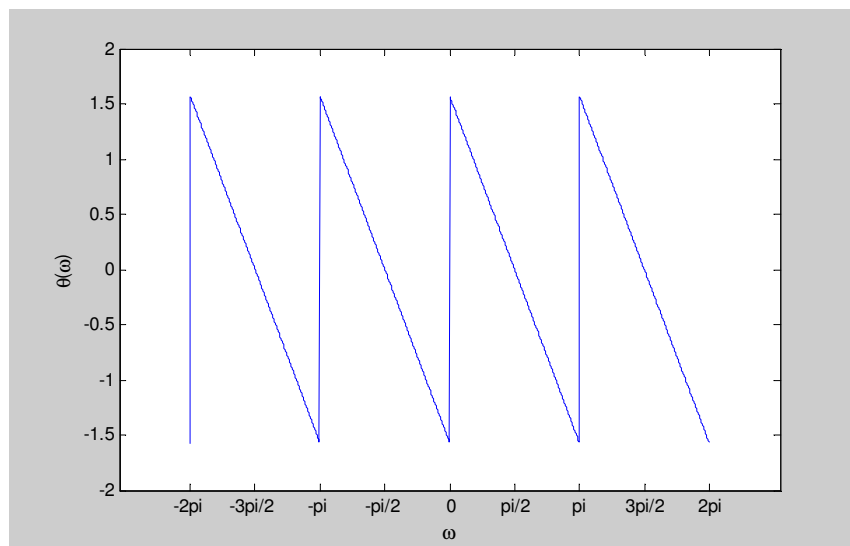
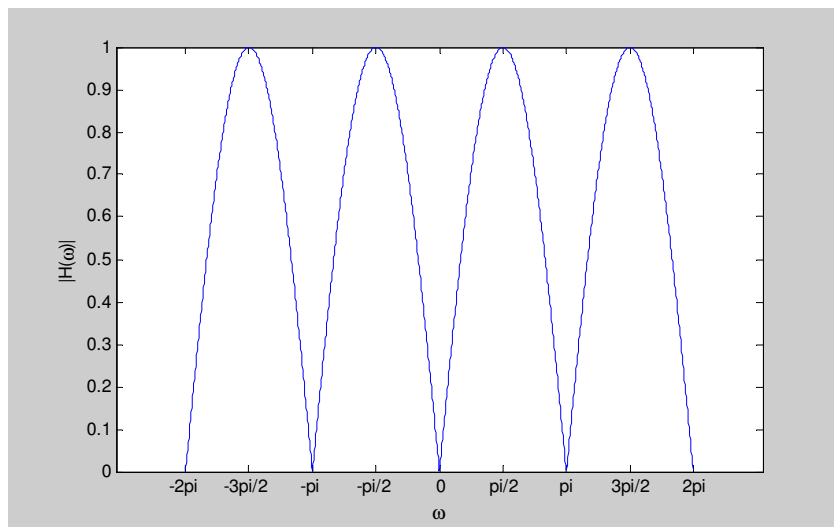

(1) The Fourier transform of the signal $y(n) = x(n - 4)$ is $Y(\omega) = \exp(-j4\omega) \cdot X(\omega)$ and the corresponding filter is $H(\omega) = \frac{Y(\omega)}{X(\omega)} = \exp(-j4\omega)$

Therefore

$$|H(\omega)| = 1 \quad \text{and} \quad \theta(\omega) = -4\omega$$

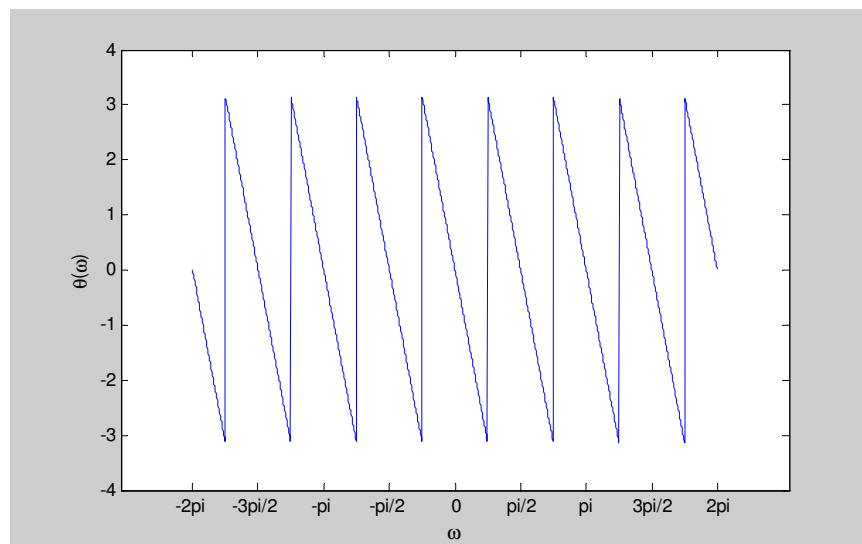
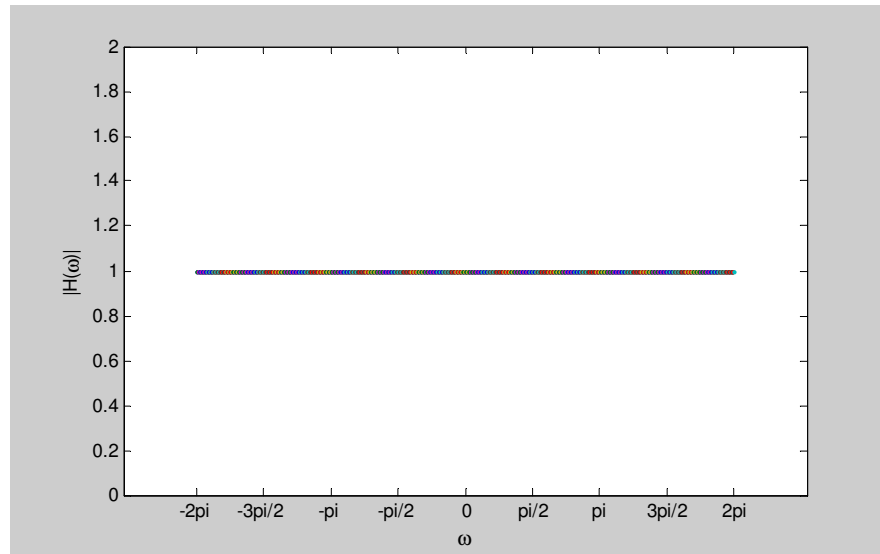

5.11

The Fourier transform of the signal $y(n) = x(n) + x(n - M)$ is $Y(\omega) = X(\omega) + \exp(-jM\omega) \cdot X(\omega)$ and the corresponding filter is

$$\begin{aligned} H(\omega) &= \frac{Y(\omega)}{X(\omega)} = 1 + \exp(-jM\omega) = \exp\left(-j\frac{M}{2}\omega\right) \cdot \left[\exp\left(j\frac{M}{2}\omega\right) + \exp\left(-j\frac{M}{2}\omega\right) \right] \\ &= \exp\left(-j\frac{M}{2}\omega\right) \cdot 2 \cdot \cos\left(\frac{M}{2}\omega\right) \end{aligned}$$

Therefore

$$|H(\omega)| = \left| 2 \cdot \cos\left(\frac{M}{2}\omega\right) \right| \quad \text{and} \quad \theta(\omega) = -\frac{M}{2}\omega$$

Because $H(\omega)$ is function of a cosine, it equals 0 when $\frac{M}{2}\omega = (2k+1)\frac{\pi}{2}$ with $k \in \mathbb{Z}$ or

$$\omega = \frac{(2k+1)\pi}{M} \quad \text{with } k \in \mathbb{Z}.$$

5.65

(a) We are given the signal $y(n) = x(n) - 0.95x(n-6)$ that has the Z-transform:

$$Z[y(n)] = Y(z) = X(z) \cdot (1 - 0.95z^{-6}).$$

Therefore the corresponding filter becomes $H(z) = \frac{Y(z)}{X(z)} = 1 - 0.95z^{-6}$ that is equivalent to:

$$H(z) = \frac{z^6 - 0.95}{z^6}$$

There exists a zero for this filter for $z^6 = 0.95$ or $z = (0.95)^{\frac{1}{6}} \cdot \exp\left(j\frac{2\pi k}{6}\right)$, $k \in \mathbb{Z}$

There also exists a pole for $z^6 = 0$ i.e. $z = 0$ is a 6th order pole for this filter.

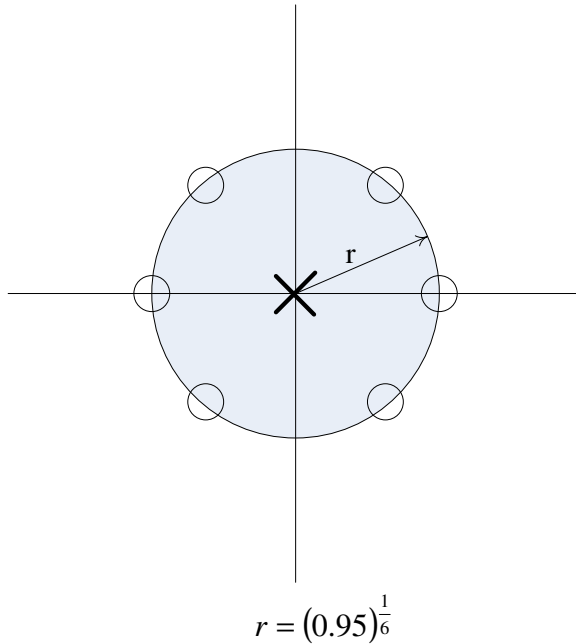

(c) The inverse system corresponds to:

$$H_{inv}(z) = \frac{z^6}{z^6 - 0.95}$$

r

This time, there exists a pole for this filter for $z^6 = 0.95$ or $z = (0.95)^{\frac{1}{6}} \cdot \exp\left(j \frac{2\pi k}{6}\right)$, $k \in \mathbb{Z}$

There also exists a zero for $z^6 = 0$ i.e. $z = 0$ is a 6th order zero for this filter.

